

Fig.1 Cut backof Filament voltage onoperationcondition

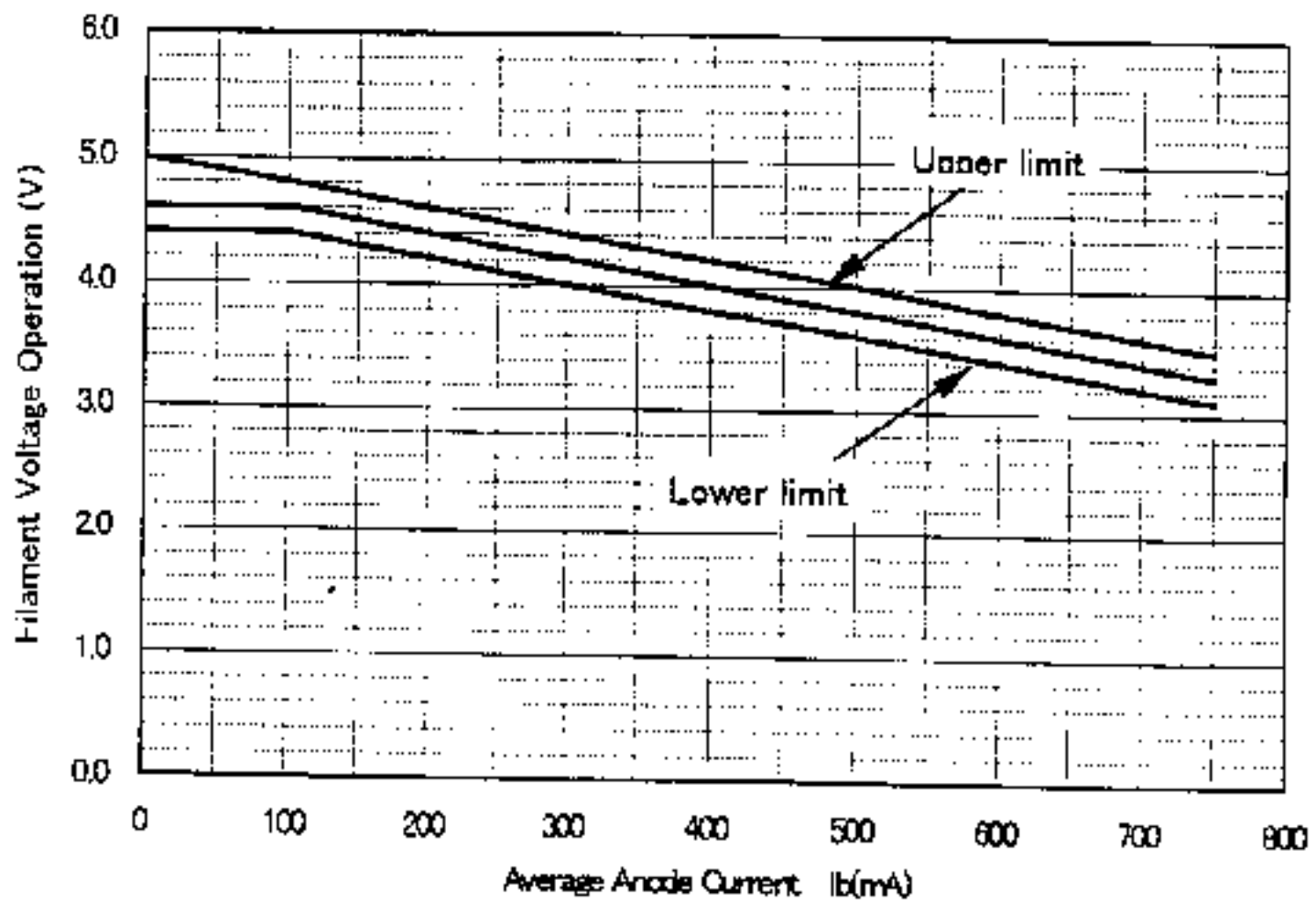
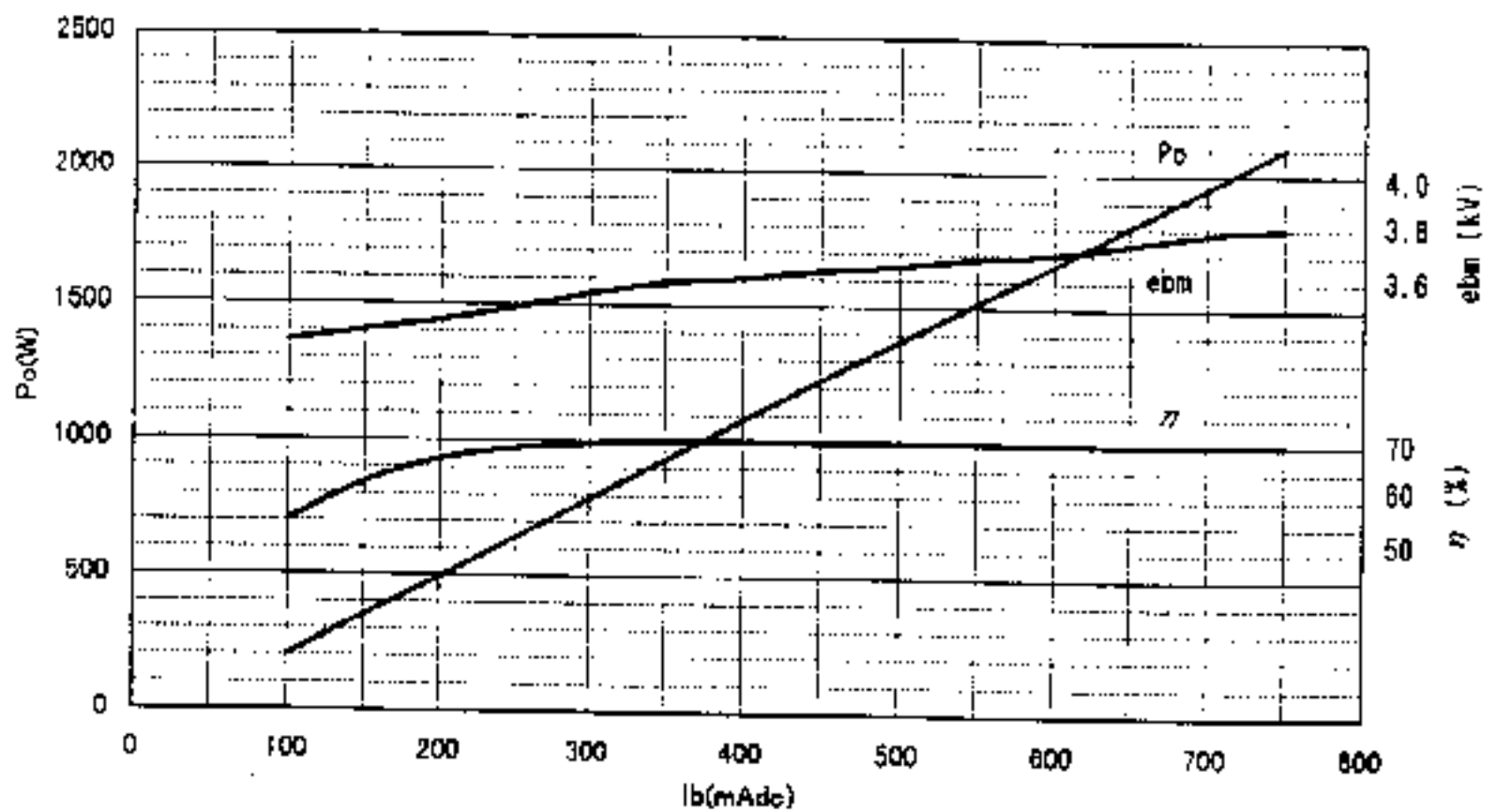

Fig.2 Performance Chart



OUTLINE DRAWING

Spec No.

807201 D

Model No.

2M259-M12

Page

9/11

Unit: mm (inch)

Note1. Anode temperature measuring point. To be measured at the outlet side of air flow.

Note2. Filter case temperature measuring point.

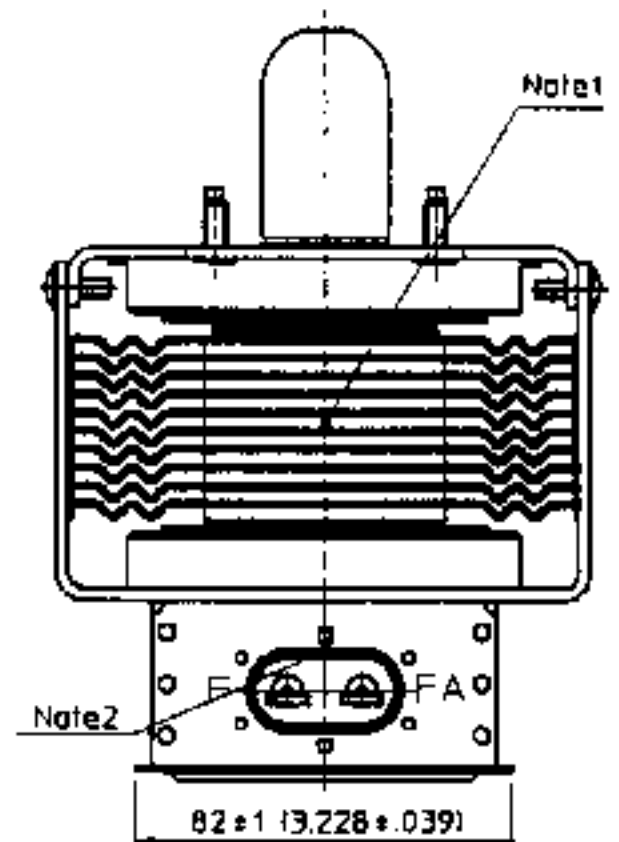
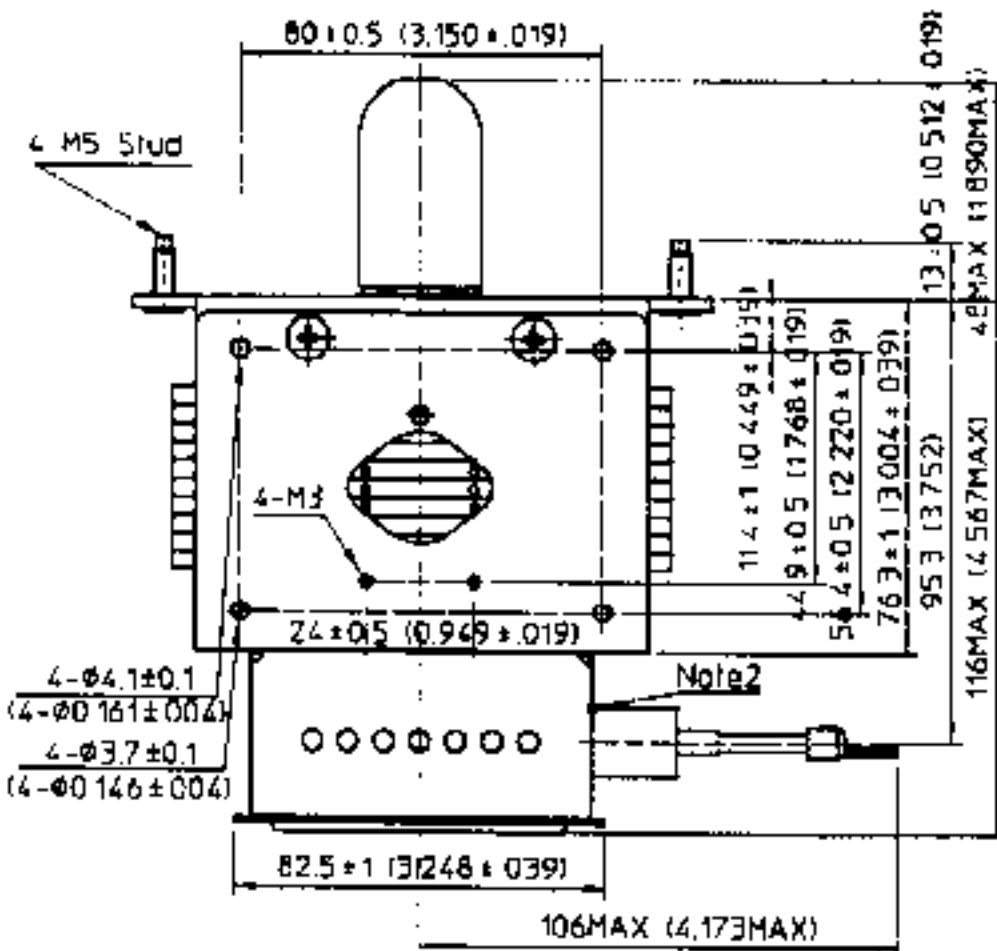
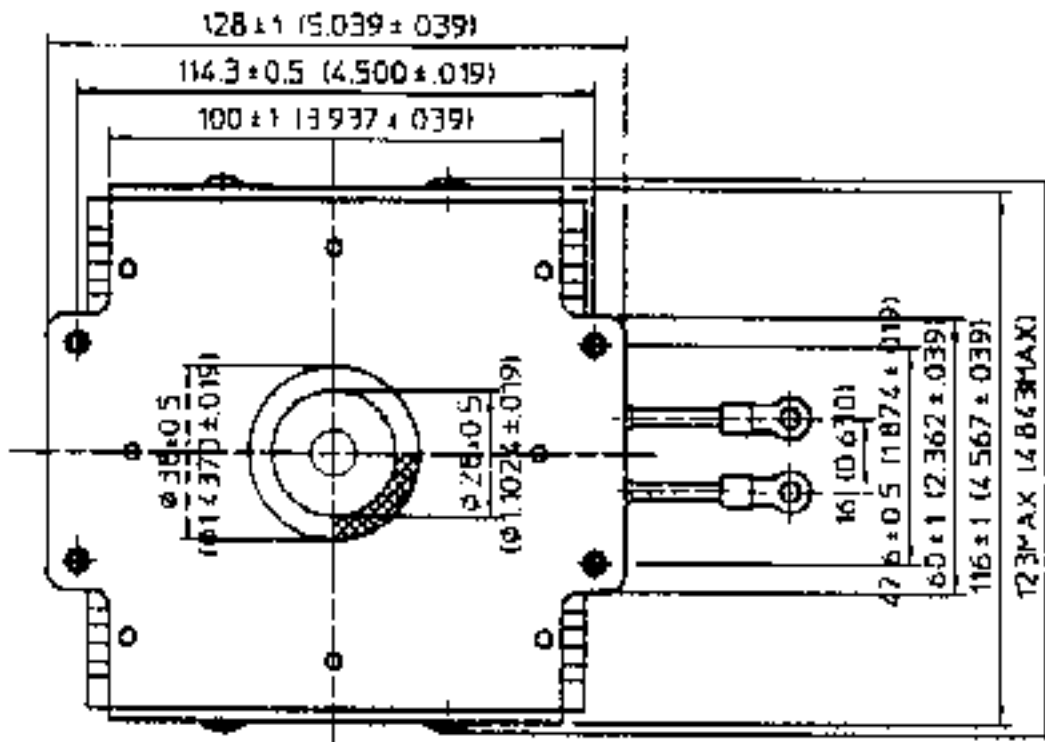

10/8/99

National/Panasonic